

Overview of LA2Xi, LA4X and LA12X features for integration with Voice Alarm systems

General layout

Comprehensive monitoring for integration of an L-Acoustics system with a Voice Alarm system requires:

- a third-party Central Control Unit (CCU, for example Crestron, Q-SYS, Extron, etc.) supporting the L-Acoustics L-COM protocol, or SNMP
- on-site calibration of nominal system conditions and failure state conditions

General layout

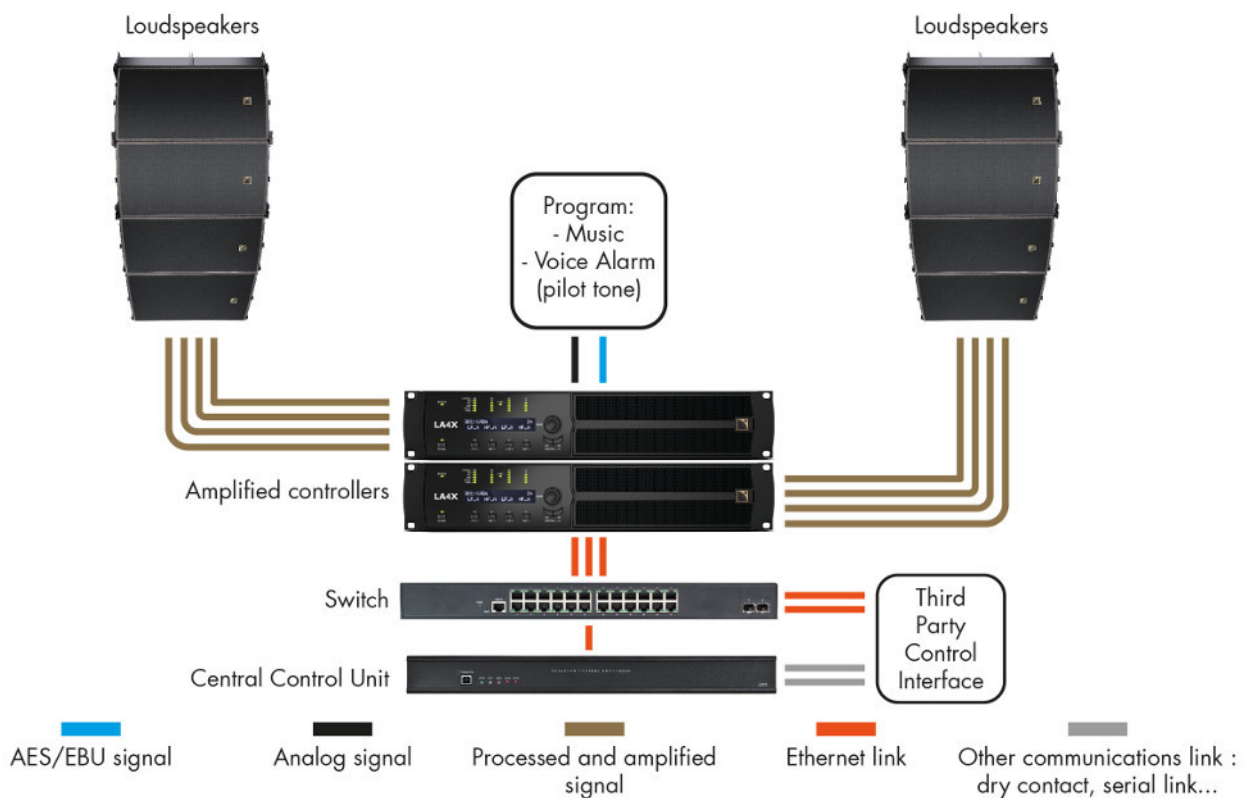

Crestron is a trademark or registered trademark of Crestron Electronics, Inc. in the United States, other countries or both.

Extron is a registered trademark of Extron Electronics.

QSC® and Q-SYS™ are trademarks or registered trademarks of QSC, LLC in the U.S. Patent and Trademark Office and other countries.

System monitoring

System monitoring provided by LA2Xi, LA4X and LA12X amplified controllers.

function	LA2Xi	LA4X	LA12X
Real-time load presence and short-circuit detection on output channel	Yes ¹	Yes ¹	Yes ¹
Periodic silent test of output circuit	Yes	Yes	Yes
AES/EBU input signal presence and error detection	Yes	Yes	Yes
Pilot tone detection on active inputs	Yes	Yes	Yes
Power amplifier failure detection	Yes	Yes	Yes
Power supply failure detection	Ext ²	Ext ²	Yes

Ethernet control network

Ethernet control network for LA2Xi, LA4X and LA12X amplified controllers.

	LA2Xi	LA4X	LA12X
type of network	Local Area Network with up to 253 amplified controllers		
Ethernet ports	two, up to 1 Gb/s		
cabling	CAT5e cable (or higher), max length = 100 m / 328 ft ³ , RJ45 connectors		

Power statuses and cascaded links

Consequences of power statuses on cascaded links.

amplified controller	link	powered on and idle	standby	powered off	power cord removed
LA2Xi	AVB/Ethernet	refreshed	refreshed	n/a	refreshed ⁴
	AES/EBU	refreshed	refreshed	n/a	ok
	analog	ok	ok	n/a	ok
LA4X	AVB/Ethernet	refreshed	refreshed	interrupted	interrupted
	AES/EBU	refreshed	refreshed	ok	ok
	analog	ok	ok	ok	ok
LA12X	AVB/Ethernet	refreshed	refreshed	interrupted	interrupted
	AES/EBU	refreshed	refreshed	ok	ok
	analog	ok	ok	ok	ok

¹ on condition that output delivers at least 1 W / 4 Ω

² to be periodically tested by Central Control Unit

³ Typical. May be extended using third-party fiber optic interfaces.

⁴ when 24V DC power is present. If not, Ethernet is interrupted.

Signal inputs

Signal inputs of LA2Xi, LA4X and LA12X amplified controllers.

	LA4X	LA12X	LA2Xi
analog audio inputs	4 balanced analog inputs line level up to +22 dBu 4 female XLR connectors 4 male XLR for passive link		4 balanced analog inputs line level up to +22 dBu 4 3-pin terminal block connectors External passive linking is possible
digital audio inputs	2 AES/EBU inputs (110 Ω) 2 female XLR, shared with analog inputs 1 and 3 2 male XLR for active link with failover relay, shared with analog links 1 and 3		2 AES/EBU inputs (110 Ω) 2 3-pin terminal block connectors, share with analog inputs 1 and 3 2 3-pin terminal block connectors for active link with failover relay
simultaneously active inputs	up to 4, analog or digital, selection by pair		
AVB digital audio inputs	4 channels 48 kHz / 96kHz from 1 AVB stream of up to 8 channels	AVB input with support of Milan seamless dual networking 4 channels 48kHz / 96 kHz from 1 AVB stream of up to 8 channels	
input mixing	yes: by pair, sum or difference of the channels of the active inputs		
analog cabling	recommended maximum length: up to 100 m / 328 ft (typical) recommended maximum number of cascaded links: 22		
digital cabling	tested max. length: 305 m / 1000 ft (at Fs = 48 kHz) with selected AES/EBU rated cables recommended maximum number of cascaded links: 22		

Automatic fallback

The AVB automatic fallback feature allows for input signal redundancy where AVB is used as a primary signal, and AES/EBU or analog inputs are used as a backup signal. In case of error, the input mode instantaneously switches over to the fallback inputs.

In case when Milan seamless redundancy is used, an error on one of the redundant AVB networks causes no audio interruption.

Additionally, the AES/EBU automatic fallback feature allows for input signal redundancy where AES/EBU is used as primary signal. In case of error, the input mode instantaneously switches over to the fallback input (secondary AES/EBU or analog input (less than 135 ms of audio interruption).

automatic fallback mode (built-in)	LA2Xi	LA4X	LA12X
Milan seamless redundancy	yes	no	yes
AVB to AES/EBU or analog	yes, 4 channels		
AES/EBU to analog	yes, 2 channels		
AES/EBU to AES/EBU	yes, 2 channels		

Alternative modes where analog is used as a primary signal may be implemented by integrators based on pilot tone detection and input selection management by Central Control Unit:

programmable fallback mode (managed by CCU)	LA2Xi	LA4X	LA12X
analog to AES/EBU	yes, 2 channels		
analog to analog	yes, 2 channels		

Status change time

	LA2Xi	LA4X	LA12X
OFF to ON	7 s	5 s	9 s
STANDBY to ON	2 s	5 s	5 s
DC24V to ON	1.5 s	-	-
ON to STANDBY	< 0.5 s	< 0.5 s	< 0.5 s
ON to OFF	< 0.5 s	< 1.5 s	approx. 20 s ⁵

Power and UPS sizing

This table presents the power consumption for each amplified controller for a typical musical program in nominal conditions, in idle mode, and in standby mode, for various nominal loads and with 230 V mains.

The calculator is available at www.l-acoustics.com/en/installation/tools/.

		1/8 max power (-9dB)			idle		standby	
amp	4 ch. loaded at	current draw (A)	thermal load (W)	thermal load (BTU/hr)	current draw (A)	thermal load (W)	current draw (A)	thermal load (W)
LA2Xi	4 Ω in SE or PBTL mode, or 8 Ω in BTL mode	2.3 A	110 W	375 BTU/hr	0.5 A	28 W	0.4 A	12 W
	8 Ω in SE mode	1.6 A	80 W	273 BTU/hr	0.5 A	28 W	0.4 A	12 W
	16 Ω in SE mode	1.2 A	55 W	188 BTU/hr	0.5 A	28 W	0.4 A	12 W
LA4X	4 or 8 Ω	3 A	250 W	853 BTU/hr	0.9 A	60 W	0.7 A	11 W
LA12X	2.7 Ω	11.5 A	750 W	2559 BTU/hr	1 A	160 W	0.6 A	10 W
	4 Ω	8.1 A	550 W	1877 BTU/hr	1 A	160 W	0.6 A	10 W
	8 Ω	4.8 A	350 W	1194 BTU/hr	1 A	160 W	0.6 A	10 W

⁵ audio instantaneously cut when switching to OFF

Third-party control systems

Functions available from third-party control systems using L-COM protocol or SNMP.

status information and monitoring (read only)	commands (write)
<ul style="list-style-type: none"> • amplified controller type • current operating mode: standby, active • full reporting of errors • current input mode and status, fallback status • current preset name, family, output names • name of next available preset • signal level / limit / clip • front panel keys locked/unlocked 	<ul style="list-style-type: none"> • standby / wake-up • input mode selection • preset load • mute/unmute, output gain control • lock/unlock front panel keys • output gain

Settings protection

In order to ensure the integrity of a fire alarm system, access to the amplified controllers parameters has to be restricted. These parameters can be protected independently from:

- LA Network Manager and amplified controller front panel access
- third-party control system application using a specifically determined access policy

Settings Protection is based on three levels of users.

When Settings Protection is enabled by the Administrator:

only the Administrator can	the Advanced User can (with the PIN code)	the General User can
<ul style="list-style-type: none"> • load non-authorized Session files • delete a user preset • reset Units to factory default parameters • update firmware • use quick access to gain from front panel 	<ul style="list-style-type: none"> • load a factory preset • store a preset • modify any group parameter • modify a preset parameter • access M1 • modify the IP address of a Unit 	<ul style="list-style-type: none"> • load authorized Session files • restore Session • load user presets • select the input mode • mute/solo • set in standby / wake-up

Access rights have been defined by L-Acoustics to meet the needs of 90% of the fixed installation applications. This policy cannot be modified by the Administrator.

For any specific need please contact L-Acoustics Application Team (applications@l-acoustics.com).

Appendix

Rear connection panels

The amplified controller's rear side features connectors for audio and network cabling:

1. For connection to the loudspeakers.
2. For connection of the analog and digital (AES/EBU or S/PDIF) audio sources, and/or for linking the signals to another amplified controller.
3. For connection to an AVB network, and to be remotely controlled by LA Network Manager.

LA4X audio and network connection panels

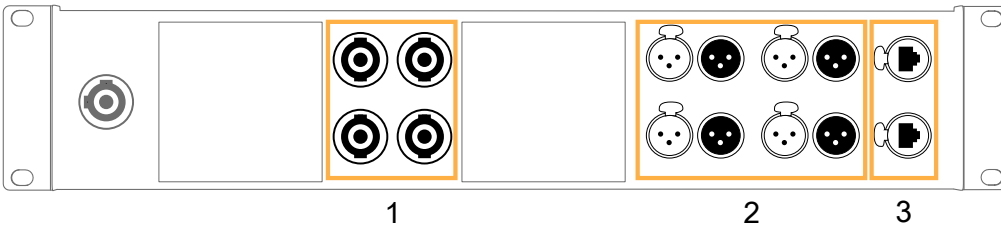

LA12X audio and network connection panels

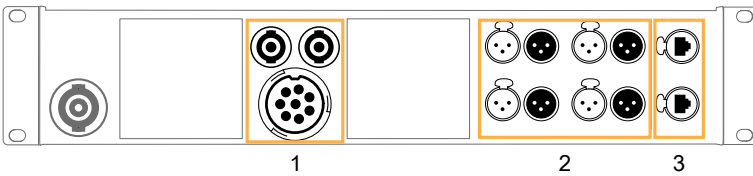

LA2Xi audio and network connection panels

