

MINI COLOR 7TC

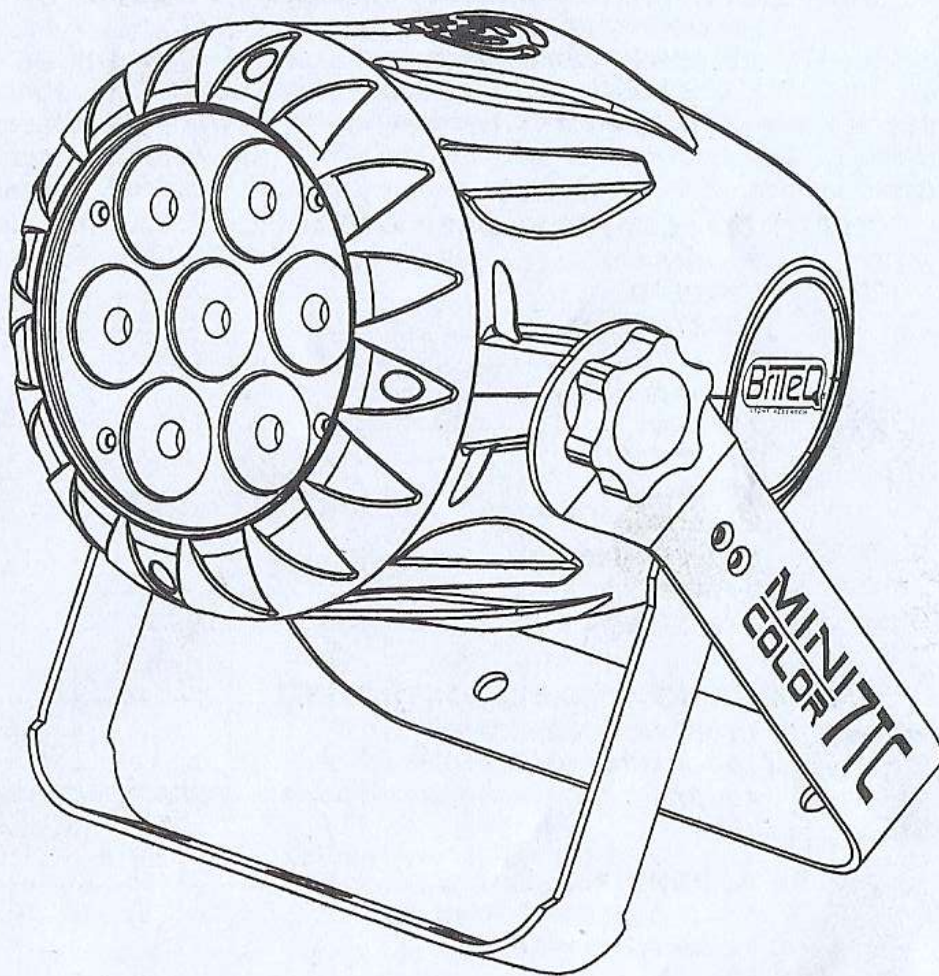

BriteQ[®]
LIGHT RESEARCH

USER
MANUAL
VER 1.0

T ABLE OF CONTENTS

PART 1 PRODUCT (GENERAL)	1.
1.1--PRODUCT INTRODUCTION.....	1.
1.2--PRODUCT FEATURES.....	1.
1.3--TECHNICAL SPECIFICATIONS.....	2.
1.4--PHOTOMETRIC DATA.....	3.
1.5--SAFETY WARNING.....	4.
PART 2 INSTALLATION	5.
2.1--MOUNTING.....	5.
2.2--POWER CONNECTION.....	5.
2.3--SETTING UP WITH A DMX512 CONTROLLER.....	6.
2.3-1--DMX512 ADDRESSING WITHOUT ID ADDRESSING.....	6.
2.3-2--DMX512 ADDRESSING WITH ID ADDRESS.....	6.
PART 3 DISPLAY PANEL OPERATION	8.
3.1--BASIC.....	8.
3.2--MENU.....	9.
3.3--STATIC.....	10.
3.4--AUTO.....	10.
3.5--ADDRESS.....	10.
3.6--RUN.....	11.
3.7--PERSON.....	11.
3.8--ID.....	11.
3.9--EDIT.....	11.
3.10--SETTINGS.....	12.
3.11--PASSWORD.....	12.
3.12--SAVE.....	12.
PART 4 USING A DMX512 CONTROLLER	13.
4.1--BASIC ADDRESSING.....	13.
4.2--CHANNEL ASSIGNMENT.....	13.
4.3--BASIC INSTRUCTIONS FOR DMX512 OPERATION (STAGE 1).....	16.
PART 5 APPENDIX	17.
5.1--TROUBLE SHOOTING.....	17.
5.2--MAINTENANCE.....	18.

1 PRODUCT (GENERAL)

1.1 PRODUCT INTRODUCTION

This product is designed for indoor use. Suitable applications include wash or effect lighting for architectural, stage or nightclub applications. This product can also be installed for use in signage and advertising using the dynamic functions available with DMX512 control. Direct input of DMX512 signal allows the units to be controlled from any DMX512 controller. This product can be operated as a single unit or in multiple units for large applications.

The specially developed controller that allows the product to be controlled independent of the DMX512 controller enables the user to create and edit a wide range of custom programs. All programs can be touch-button displayed or scheduled to START and END at scheduled times. When programs have been created or edited in the controller, it is also possible to trigger these programs using the DMX IN function when connected to a DMX512 controller.

1.2 PRODUCT FEATURES

LED FIXTURE

- * RGB Dimmer 0-100%
- * Strobe
- * Automatic programs
- * LCD display
- * Display control 'lock-out'
- * Direct DMX512 input
- * Independent ID address
- * Stand-alone/ Slave

1.3 TECHNICAL SPECIFICATIONS

LED MODULE

LED MODULE:	
Voltage	100-240V...50/60Hz
Rated Power	35W
LED/Unit	7 X 3W Tri-LED
Environment Temperature	-20°C~40°C
Cooling	Forced air convection
Dimensions	240 x 210 x 160mm
Weight	2.5Kg

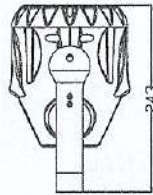
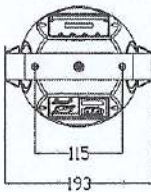
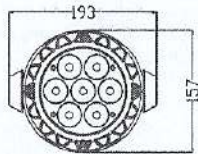

1.4 PHOTOMETRIC DATA

PHOTOMETRIC DATA

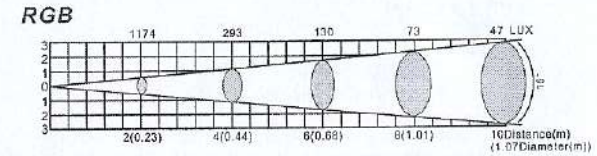
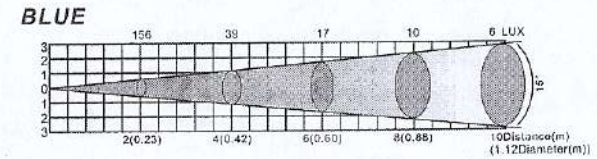
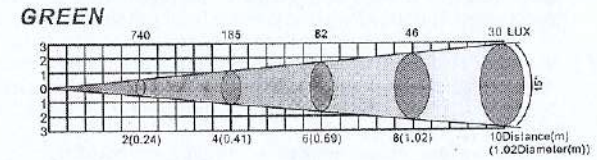
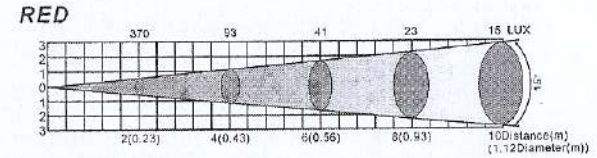

1.5 SAFETY WARNING

IMPORTANT

[ALWAYS READ THE USER MANUAL BEFORE OPERATION.]
[PLEASE CONFIRM THAT THE POWER SUPPLY STATED ON THE PRODUCT IS THE SAME AS THE MAINS POWER SUPPLY IN YOUR AREA.]

- This product must be installed by a qualified professional.
- Always operate the equipment as described in the user manual.
- A minimum distance of 0.5m must be maintained between the equipment and combustible surface.
- The product must always be placed in a well ventilated area.
- Always make sure that the equipment is installed securely.
- DO NOT stand close to the equipment and stare directly into the LED light source.
- Always disconnect the power supply before attempting and maintenance.
- Always make sure that the supporting structure is solid and can support the combined weight of the products.
- The earth wire must always be connected to the ground.
- Do not touch the power cables if your hands are wet.

ATTENTION

ATTENTION

- This product left the place of manufacture in perfect condition. In order to maintain this condition and for safe operation, the user must always follow the instructions and safety warnings described in this user manual.
- Avoid shaking or strong impacts to any part of the equipment.
- Make sure that all parts of the equipment are kept clean and free of dust.
- Always make sure that the power connections are connected correct and secure.
- If there is any malfunction of the equipment, contact your distributor immediately.
- When transferring the product, it is advisable to use the original packaging in which the product left the factory.
- Shields, lenses or ultraviolet screens shall be changed if they have become damaged to such an extent that their effectiveness is impaired.
- The lamp (LED) shall be changed if it has become damaged or thermally deformed.

2 INSTALLATION

2.1 MOUNTING

HANGING

The LED PAR can be mounted in a hanging position using the supporting bracket. The bracket should be secured to the mounting truss or structure using a standard mounting clamp. Please note that when hanging the unit a safety cable should also be used.

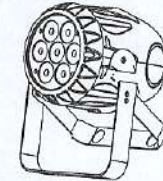

UPRIGHT

The LED PAR can be mounted in an upright or sitting position using the supporting brackets.

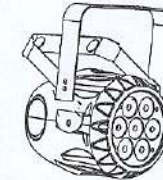

NOTE The LED MODULE can be mounted at any angle and in any position. It is possible to further adjust the angle of the LED MODULE using the two adjustment knobs located on the side of the fixture.

2.2 POWER CONNECTIONS

@ 220V: 40 units may be connected in series

@ 120V: 20 units may be connected in series

Note: As this fixture's DMX signal cable connection had been changed to Parallel connection, so if over 30 units to be connected, then a DMX signal amplifier is needed.

2.3 SETTING UP WITH A DMX512 CONTROLLER

2.3-1 DMX512 ADDRESSING WITHOUT ID ADDRESSING (STAGE 1 MODE)

- Connect the DMX512 controller to the units in series.
- Each unit has 9 DMX channels so the DMX Addresses should increase by increments of 9 (e.g. 1,10,19,28...)
- The ID address has not been set so therefore when using the controller Ch9 must be inactive (CH9=0).
- Each DMX Address may be used as many times as required.
- Any DMX Address in the range from 001 to 512 may be used.

Example:

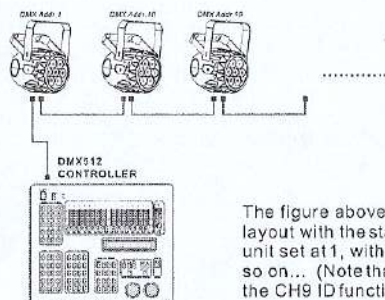

The figure above shows a simple DMX512 layout with the starting address of the first unit set at 1, with the second set at 10 and so on... (Note that when used in this way, the CH9 ID function must be inactive (CH9=0))

2.3-2 DMX512 ADDRESSING WITH ID ADDRESS (STAGE 1 MODE)

- Connect the DMX512 controller to the units in series.
- Each unit has 9 DMX channels so the DMX Addresses should increase by increments of 9 (e.g. 1,10,19,28...)
- Each DMX Address may be used as many times as required.
- Any DMX address in the range from 001 to 512 may be used.
- Each DMX address may carry up to 66 separate ID addresses.
- **[ID]** should be set in the menu on each unit in ascending values (i.e. 1,2,3...)
- ID addresses are accessible from Ch9 on the DMX512 controller.

Example:

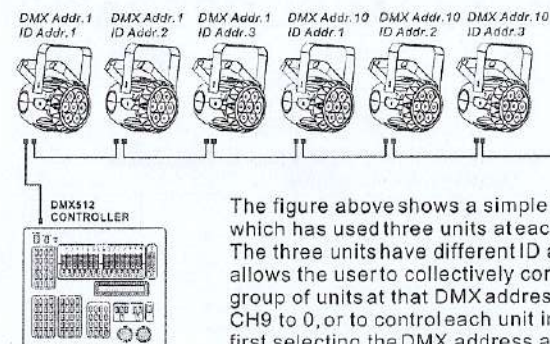

The figure above shows a simple DMX layout which has used three units at each DMX address. The three units have different ID addresses which allows the user to collectively control the whole group of units at that DMX address by setting CH9 to 0, or to control each unit independently by first selecting the DMX address and then by using CH9 to locate the target ID address.

3 DISPLAY PANEL OPERATION

3.1 BASIC

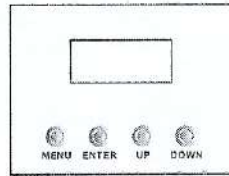

- 【 MENU 】 scroll through the main menu or exit from the current menu or function
- 【 ENTER 】 Enter the currently selected menu or confirm the current function value
- 【 UP 】 scroll 'UP' through the menu list or increase the value of the current function
- 【 DOWN 】 scroll 'DOWN' through the menu list or decrease the value of the current function

3.2 MENU

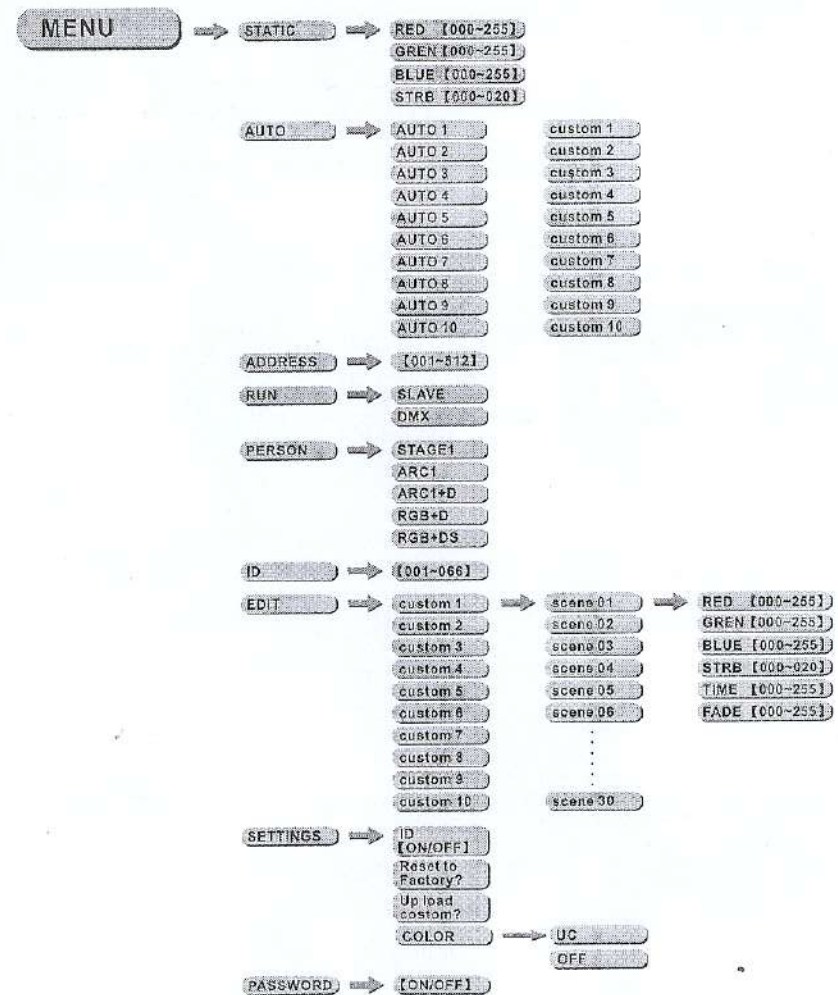

3.3 STATIC



[STATIC]

- Select **[RED]** / **[GREEN]** / **[BLUE]** / **[STRB]** to set the value

3.4 AUTO

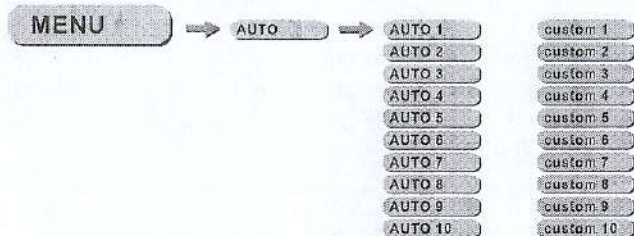

[AUTO]

- Select the target **[AUTO]** program and press **[ENTER]**
- Programs **[AUTO 1]** to **[AUTO 10]** are fully pre-programmed and will not be altered
- Programs **[Custom 1]** to **[Custom 10]** are fully pre-programmed and can be edited

3.5 ADDRESS



[ADDRESS]

- Enter **[ADDRESS]** and set the DMX address **[001-512]**

3.6 RUN



[RUN]

- Enter **[RUN]** to choose **[SLAVE]** or **[DMX]** working mode

3.7 PERSON

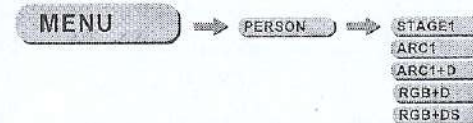

[PERSON]

- Enter **[PERSON]** and select **[STAGE1]** / **[ARC1]** / **[ARC1+D]** / **[RGB+D]** / **[RGB+DS]** DMX mode

3.8 ID



[ID]

- Enter **[ID]** and set the ID address **[001-066]**

3.9 EDIT

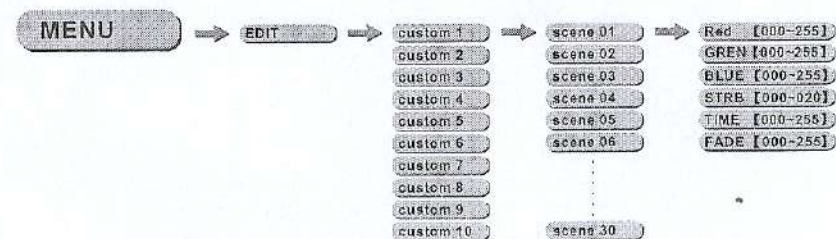

[EDIT]

- Enter **[EDIT]** to edit the custom programs **[custom 1]** to **[custom 10]**
- Each program has 30 steps to edit
- Each step allows a creation of a scene using RED, GREEN, BLUE, STRUBE, TIME, FADE

3.10 SETTINGS

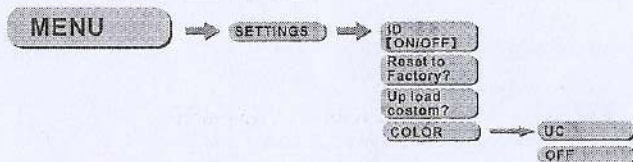

【ID】

- Choose **【ON】** / **【OFF】** to open or close ID

【Reset to Factory?】

- This function will reset all setting to the original factory setting

【Up load custom?】

- Select **【Up load custom?】** to upload the custom programs from the current MASTER unit to the SLAVE units

- **【COLOR】** is for activate/unactivate the color calibration functions. When **【UC】** is selected, the RGB output are adjusted to a standard preset universal color which balances fixtures from different generations. The factory default setting is **【UC】** on.

3.11 PASSWORD



【PASSWORD】

- Enter the **【PASSWORD】** mode to select whether the access password is on or off.
- When the fixture is set as PASS **【ON】**, after 30 seconds or turn on the fixture next time, the fixture will need an access password to enter the display menu control.

Note: The factory access password is **【UP】 + 【DOWN】 + 【UP】 + 【DOWN】**, then press **【ENTER】** to confirm the access.

3.12 SAVE

- Only the main menu and the Auto-programs submenu can be protected
- Repower the unit, it will back to the main menu

4 USING A DMX512 CONTROLLER

4.1 BASIC ADDRESSING

- Connect all of the units in series using standard DMX512 signal cable or the IP65 rated cable provided.
- Set the DMX512 address in the **【DMX】** menu.

4.2 CHANNEL ASSIGNMENT

- Note: This product have three DMX512 channel configuration: **【STAGE 1】**, **【ARC 1】**, **【ARC 1+D】**, **【RGB+D】** and **【RGB+DS】**

STAGE 1

CHANNEL	VALUE	FUNCTION
1	0 ↔ 255	DIMMER
2	0 ↔ 255	RED
		Ch2 will control the TIME if Ch7 choose custom01-10
3	0 ↔ 255	GREEN
		Ch3 will control the FADE if Ch7 choose CUSTOM01-10
4	0 ↔ 255	BLUE
5	0 ↔ 10	MARCO No function
	11 ↔ 35	RED 100% / GREEN UP / BLUE 0%
	36 ↔ 60	RED DOWN / GREEN 100% / BLUE 0%
	61 ↔ 85	RED 0% / GREEN 100% / BLUE UP
	86 ↔ 110	RED 0% / GREEN DOWN / BLUE 100%
	111 ↔ 135	RED UP / GREEN 0% / BLUE 100%
	136 ↔ 160	RED 100% / GREEN 0% / BLUE DOWN
	161 ↔ 185	RED 100% / GREEN UP / BLUE UP
	186 ↔ 210	RED DOWN / GREEN DOWN / BLUE 100%
	211 ↔ 215	WHITE 1: 3200K
	216 ↔ 220	WHITE 2: 3400K
	221 ↔ 225	WHITE 3: 4200K
	226 ↔ 230	WHITE 4: 4900K
	231 ↔ 235	WHITE 5: 5000K
236 ↔ 240	WHITE 6: 5900K	
241 ↔ 245	WHITE 7: 6500K	
246 ↔ 250	WHITE 8: 7200K	
251 ↔ 255	WHITE 9: 8600K	
6	0 ↔ 10	STROBE No function
	11 ↔ 255	Strobe speed

CHANNEL	VALUE	FUNCTION
7		AUTO
	0 ↔ 20	No function
	21 ↔ 30	AUTO 1
	31 ↔ 40	AUTO 2
	41 ↔ 50	AUTO 3
	51 ↔ 60	AUTO 4
	61 ↔ 70	AUTO 5
	71 ↔ 80	AUTO 6
	81 ↔ 90	AUTO 7
	91 ↔ 100	AUTO 8
	101 ↔ 110	AUTO 9
	111 ↔ 120	AUTO 10
	121 ↔ 130	CUSTOM 1
	131 ↔ 140	CUSTOM 2
	141 ↔ 150	CUSTOM 3
	151 ↔ 160	CUSTOM 4
	161 ↔ 170	CUSTOM 5
	171 ↔ 180	CUSTOM 6
	181 ↔ 190	CUSTOM 7
	191 ↔ 200	CUSTOM 8
	201 ↔ 210	CUSTOM 9
	211 ↔ 220	CUSTOM 10
221 ↔ 255	No function	
8		AUTO SPEED ADJUSTMENT
	0 ↔ 255	When using CH7/AUTO01-AUTO9, this function activated
9		ID ADDRESS
	0 ↔ 9	ID1-ID65
	10 ↔ 19	ID1
	20 ↔ 29	ID2
	30 ↔ 39	ID3
	40 ↔ 49	ID4
	50 ↔ 59	ID5
	60 ↔ 69	ID6
	70 ↔ 79	ID7
	80 ↔ 89	ID8
	90 ↔ 99	ID9
	100 ↔ 109	ID10
	110 ↔ 119	ID11
	120 ↔ 129	ID12
	130 ↔ 139	ID13
	140 ↔ 149	ID14
	150 ↔ 159	ID15
	160 ↔ 169	ID16
	170 ↔ 179	ID17
180 ↔ 189	ID18	
190 ↔ 199	ID19	

CHANNEL	VALUE	FUNCTION
9	200 ↔ 209	ID20
	210	ID21
	211	ID22
	⋮	⋮
	253	ID64
	254	ID65
	255	ID65

ARC 1

CHANNEL	VALUE	FUNCTION
1	0 ↔ 255	RED
2	0 ↔ 255	GREEN
3	0 ↔ 255	BLUE

ARC 1+D

CHANNEL	VALUE	FUNCTION
1	0 ↔ 255	MASTER DIMMER
2	0 ↔ 255	RED
3	0 ↔ 255	GREEN
4	0 ↔ 255	BLUE

RGB+D

CHANNEL	VALUE	FUNCTION
1	0 ↔ 255	RED
2	0 ↔ 255	GREEN
3	0 ↔ 255	BLUE
4	0 ↔ 7	MASTER DIMMER 0%
	8 ↔ 199	MASTER DIMMER 0-100%
	200 ↔ 230	DIMMER 1 100%
	231 ↔ 242	DIMMER 1 20%
	243 ↔ 255	DIMMER 1 100%

RGB+DS

CHANNEL	VALUE	FUNCTION
1	0 ↔ 255	RED
2	0 ↔ 255	GREEN
3	0 ↔ 255	BLUE
4	0 ↔ 255	MASTER DIMMER
5	0 ↔ 7	NO function
	8 ↔ 255	0-255

4.3 BASIC INSTRUCTIONS FOR DMX512 OPERATION (STAGE 1)

MASTER DIMMER

- CH1 controls the intensity of the currently projected color
- When the slider is at the highest position (255) the intensity of the output is the maximum

RED, GREEN & BLUE COLOR SELECTION

- CH2, CH3 & CH4 control the intensity ratio of each of the RED, GREEN & BLUE LEDs.
- When the slider is at the highest position (255) the intensity of the color is the maximum.
- CH2, CH3 & CH4 can be combined together to create over 16 million colors.

COLOR MACROS

- CH5 selects the required COLOR MACRO
- CH5 has priority over CH2, CH3, CH4 and CH6
- CH1 is used to control the intensity of the COLOR MACRO

STROBE

- CH 6 controls the strobe of CH1 to Ch5

ID ADDRESS SELECTION

- CH9 is used to select the target ID address.
- Each independent DMX address may have up to 66 independent ID addresses.
- An ID address of 0 will activate all ID address locations.

AUTO

- CH7 selects the preset AUTO programs AT.01-AT10 or the custom AUTO programs PR.C1-PR.10
- When activating the custom AUTO programs PR.C1 to PR.10 then it is possible to control the Step time and fade time using Ch2 and Ch3 respectively.

5 APPENDIX

5.1 TROUBLE SHOOTING

LED MODULE

SITUATION	CAUSE	ACTION	PART ORDER NUMBER
No display	1) Power connection error	1) Check all power connections	
	2) Power switch damaged	2) Replace power switch	16-03-0030-04
	3) Display board damaged	3) Replace display board	26-2A-LED307DI-00
	4) Fuse damaged	4) Replace the Fuse	
LED MODULE on, but no control from display	1) Keyboard damaged	1) Replace keyboard	26-2A-LED307DI-00
	2) Display board damaged	2) Replace display board	26-2A-LED307DI-00
LEDs of the same color are not lit	LED PCB damaged	Check and Replace PCB board	26-2A-307LED-00
LED module on, LEDs of all colors are not lit	1) MAIN PCB damaged	1) Replace main PCB board	26-2A-LED307DI-00
	2) LED PCB damaged	2) Replace PCB board	26-2A-307LED-00
Display normal, but no response to DMX 512 controller	1) Signal connection error	1) Check and replace signal cable	
	2) DMX Address error	2) Check and reset DMX address	
	3) Master & slave mode error	3) Check and reset the working mode	
	4) ID error	4) Check and reset ID address	

5.2 MAINTENANCE

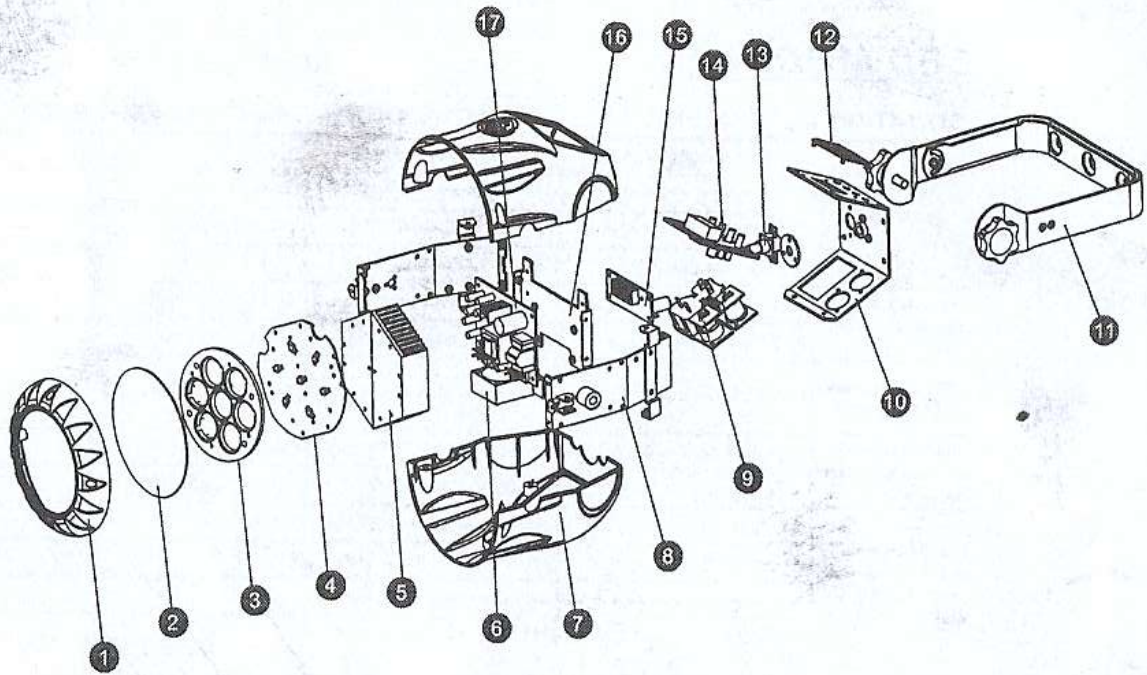

No	ITEM
1	Plastic cover
2	dustproof glass
3	Lens whed
4	Led board
5	Cooling
6	Fans
7	Plastic side cover
8	Side board
9	DMX board
10	Display support
11	Holder
12	LCD plastic cover
13	Fuse socket
14	Main board
15	Driver board
16	Power board
17	Switch