



BS 15

SINGLE CHANNEL BELTPACK



USER MANUAL

Issue 2011 © ASL Intercom BV

DESIGNED & MANUFACTURED BY:

ASL Intercom B.V.
Zonnebaan 42
3542 EG Utrecht
The Netherlands
Tel: +31 (0)30 2411901
Fax: +31 (0)30 2667373
Email: info@asl-inter.com
Web: www.asl-inter.com

CONTENT OF THIS USER MANUAL

1.0	GENERAL DESCRIPTION	3
2.0	UNPACKING	3
3.0	INSTALLATION	3
4.0	WARRANTY	3
5.0	FRONT PANEL CONTROLS	4
6.0	REAR PANEL CONNECTORS	4
7.0	INTERNAL CONTROLS	5
8.0	TECHNICAL SPECIFICATIONS	5
9.0	PARTY LINE, TECHNICAL CONCEPT	5
10.0	CABLING	6
11.0	EARTHING CONCEPT	7
12.0	SYSTEM CONFIGURATION	7
13.0	BLOCK DIAGRAM BS 15	8

1.0 GENERAL DESCRIPTION

The BS 15 is a portable single channel user station housed in a strong ABS case.

On the front panel are a Volume (listen level) control, a TALK and a CALL button both with LED indicators, a side tone trimmer and a buzzer volume.

Special attention has been paid to the intelligibility of speech. By applying low noise/high speed op-amps, a speech presence filter and a specially developed

amplifier, communication is very comfortable even in environments with a very high background noise level.

The unique ASL CALL system provides both a flashing red LED and a very distinctive and characteristic sound signal. Smooth operation is guaranteed with the CALL button. A momentary push makes the red LED flash, whilst holding the button for two seconds will activate the CALL sound signal. The volume of the sound signal (buzzer) can be adjusted

2.0 UNPACKING

The shipping carton contains the parts listed below:

- The BS 15
- This User Manual

If any are missing, contact your dealer.

ASL has taken great care to ensure this product reaches you in flawless condition.

After unpacking the unit please inspect for any physical damage to the unit, and retain the shipping carton and relevant packing materials for use should the unit need returning.

If any damage has occurred, please notify your dealer immediately so that a written claim can be initiated. Please also refer to the guarantee section of this manual.

3.0 INSTALLATION

This BS 15 will form part of an existing or new intercom system, and connection to it is straightforward. There are no separate power connections, or batteries to install, as the necessary DC voltages are derived from the intercom master station or power supply, via the intercom connection cable.

To connect the BS 15 to the intercom system, use professional flexible microphone cable with 2 wires and 1 shield only.

Connect the system intercom cable to the LINE connector on the rear panel. Finally connect the headset plug to the headset connector, also on the rear panel.

The BS 15 is fully protected against mis-wiring (reverse power) or short-circuit in the interconnecting cables.

4.0 WARRANTY

This unit is warranted by ASL Intercom to the original end-user purchaser against defects in workmanship and materials in its manufacture for a period of one year from date of shipment to the end-user.

Faults arising from misuse, unauthorized modifications or accidents are not covered by this warranty. When the unit is faulty it should be sent in its original packing, to the supplier or your local ASL dealer, with shipping prepaid. A note must be included stating the faults found and a copy of the original suppliers invoice.

5.0 FRONT PANEL CONTROLS

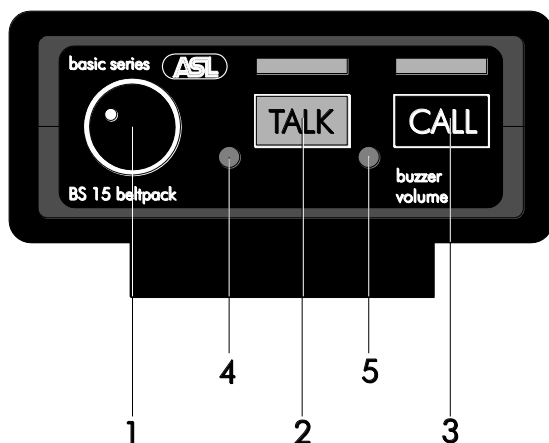

1 VOLUME control knob

This knob adjusts the listen level for the headset.

2 TALK button

This push button activates the headset microphone, the large green LED indicates if the microphone is switched on.

3 CALL button

This push button activates the call system. By a momentary push a call signal is sent to all stations connected to the intercom channel and the call LED's start flashing. Push and hold the CALL button for 2 seconds activates the call buzzer. After the CALL button is released the LED's continue to flash for a further 2 seconds.

4 SIDETONE trimmer

This trimmer adjusts the level of your own voice as you hear it in your headset.

Side tone adjustment procedure :

- set trimmer in start position : fully clockwise
- switch off the microphone of all connected (speaker) stations
- switch on the microphone of the BS 15
- turn up the volume
- speak into the headset microphone
- adjust the listen level by turning the sidetone trimmer.

The operating area is between fully clockwise and minimum level. Adjusting the sidetone does not affect the level of your voice as it is heard by other stations.

5 BUZZER VOLUME trimmer

This trimmer adjusts the volume of the internal buzzer, which is located behind the front panel. The buzzer is activated if you push the CALL button of this BS 15 (or a CALL button of any other station on the channel to which the BS 15 is connected), longer than 2 seconds.

6.0 REAR PANEL CONNECTORS

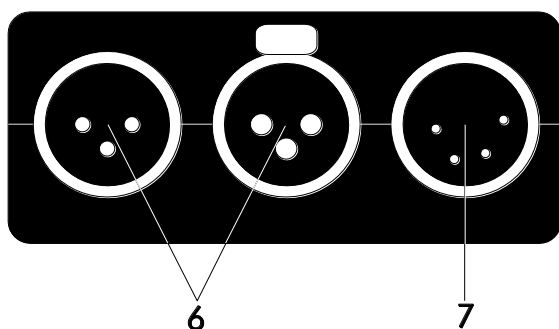

6 LINE connectors

These XLR-3 connectors are for connecting the BS 15 to the intercom system. The female connector is for input. The male connector is for extending the intercom line to other user stations ('daisy chaining').

Line connector pin assignments:

- pin 1: 0 V / ground shield
- pin 2: +30 V power wire
- pin 3: audio wire

7 HEADSET connector

An XLR-4 connector for the connection of the local headset. The headset can must have a can impedance of minimum 200 ohms, or each minimum 400 ohms when there are two cans in parallel. The mic may be of the dynamic or electret type.

Pin assignments:

- pin 1: Shield mic. (GND)
- pin 2: mic. +
- pin 3: phones +
- pin 4: phones -

7.0 INTERNAL CONTROLS

MIC GAIN

The gain for the headset mic can be adjusted internally by a trimmer. The trimmer is located on the lower PCB board.

- Open the BS 15 by removing the four screws on the underside
- To increase mic gain turn clockwise. To decrease mic gain turn counterclockwise

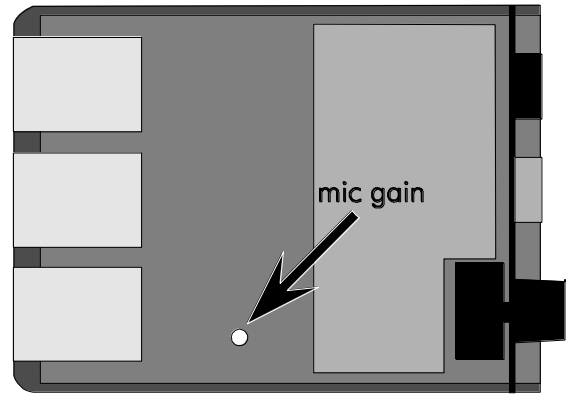

8.0 TECHNICAL SPECIFICATIONS

General System Specifications

dynamic range: 80 dB (1 kHz, THD<1%)
call signal (send): +2.8 mA
call signal threshold (receive): +2.4 V DC
supply voltage: +30 V DC (12 - 32 V DC)

Intercom Line

line impedance: 350 Ω (1kHz), 2.2 k Ω (DC)
audio level: nom. -18 dBu, max. +4 dBu

Mic. Pre-amp

mic. Impedance: 200 ohms
gain: 40 dB - 60 dB (adjustable internally)
presence filter: +6 dB at 5 kHz
frequency response: 200 Hz - 15 kHz (-3 dB)
V electret mic: +9 V DC

Headphones Driver Amp

max. load: 200 ohms
max. output level: 10.6 Vrms @200 ohms
max. output power: 0.5 Wrms @ 200 ohms

Side Tone

Rejection: 0 - 30dB adjustable

Buzzer

max. SPL: 85 dBA

Power Consumption BS 15

current (at 30 V DC) :
18 mA quiescent
35 mA signaling
80 mA at max. output + signaling

Dimensions & Weight

Width: 90 mm / Height: 38 mm
Depth: 124 mm / Weight: 260 grams

Note: 0dBu defined as 775 mV into open circuit

ASL reserves the right to alter specifications without prior notice.

9.0 PARTY LINE, TECHNICAL CONCEPT

User stations in an ASL intercom system are connected via one or several 'party lines'. A party line offers two way ('full duplex') communication and consists of standard microphone (multi-pair) cable. One wire is used as an audio line, one as a power line and the screen of the cable functions as earth/return. Current drive is used for signal transfer. Each station utilizes a current amplifier to amplify the microphone signal and place it on the common audio line where, due to the constant line impedance (situated in the power supply between XLR pin 3 and 1), a signal voltage is developed which can be further amplified and sent to the headphones.

This principle has three advantages:

- the use of a single audio line allows several stations to talk and listen simultaneously.
- due to the high bridging impedance offered by each station, the number of stations 'on line' has no influence on the level of the communications signal.
- power and audio to the intercom stations use the same cable.

The Call signal is also sent as a current on the audio line. It develops a DC potential over the line impedance which will be sensed by each station and interpreted as a Call signal.

10.0 CABLING

The intercom lines (the 'party lines') are of the shielded two-conductor microphone cable type. The intercom line connectors are of the XLR-3 type. Audio and Call signals are on pin 3, DC power is on pin 2 and pin 1 is connected to the shield of the cable which functions as the common return for audio and power.

The audio signal is transferred in an unbalanced way (see 'Party Line, Technical Concept'). To avoid earth loops (hum), the possible effect of electromagnetic fields and to minimize power loss, certain rules have to be obeyed when installing the cabling of an intercom system.

Use high quality cable

Use high quality microphone cable (shielded two conductor cable, minimum 2x 0.30 mm²). In case of a multi channel intercom network, use high quality microphone 'multi-pair' cable only, each pair consisting of two conductors (minimum 2x 0.15 mm²) with separate shield. Multi-pair cable should have an overall shield as well.

Use flexible cable

Use flexible single and multi-pair microphone cable instead of cable with solid cores, especially when the cable is subjected to bending during operation or installation.

Cable screens to XLR pin 1

The screen of each separate microphone cable and/or the screen of each single pair in a multi-pair cable, should be connected to pin 1 of each XLR-3 connector. Do not connect these screens to the metal housing of the master station or the power supply or XLR-3 wall boxes. See section 'Earthing Concept'.

Connect metal cable trunks, wall boxes and overall multi-pair cable screens to clean earth

Metal cable trunks, metal connection boxes and overall multi-pair cable screens should be interconnected and, at one point (the 'central earth point') in the intercom network only, be connected to a clean earth or a safety earth. (see section 'Earthing Concept').

Keep metal connection boxes and cable trunks or pipes isolated from other metal parts

Metal trunks or pipes for intercom cables and metal connection boxes should be mounted in such a way that they are isolated from any other metal housing or construction parts.

Keep cables parallel as much as possible

When two (multi channel) units in a network are connected by more than one cable, make sure that these cables are parallel to each other over the whole distance between those units. When using multi-pair cable, parallelism is ensured in the best possible way.

Avoid closed loops

Always avoid that intercom cables are making a closed loop. So-called 'ring intercom' should not physically be cabled as a ring..

Keep cables away from electromagnetic sources

Keep intercom cables away from high energy cables, e.g. 115/230/400V mains power or dimmer controlled feeds for spotlights. Intercom cables should cross high energy cables at an angle of 90° only. Intercom cables should never be in the same trunks as energy cables.

Place power supply in a central position

In case of a system powered by a separate power supply: In order to diminish power losses, place the power supply as close as possible to where most power consumption occurs, in other words most user stations are placed.

ASL powered units to a 'clean' mains outlet

Master stations or power supplies should be connected to a mains outlet with a clean earth. Other audio equipment may be connected to this mains outlet, but avoid using an outlet which also powers dimmer controlled lighting systems.

11.0 EARTHING CONCEPT

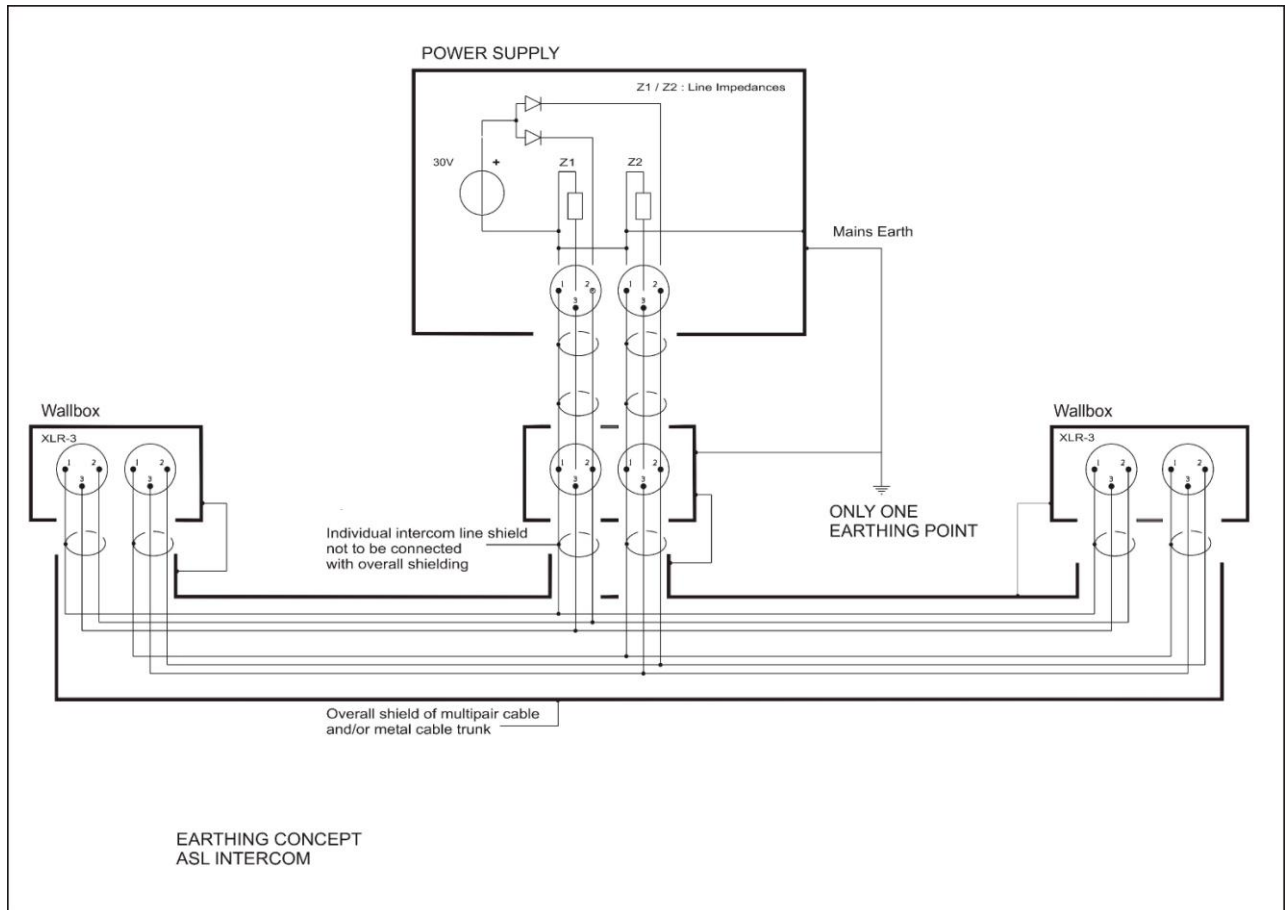

12.0 SYSTEM CONFIGURATION

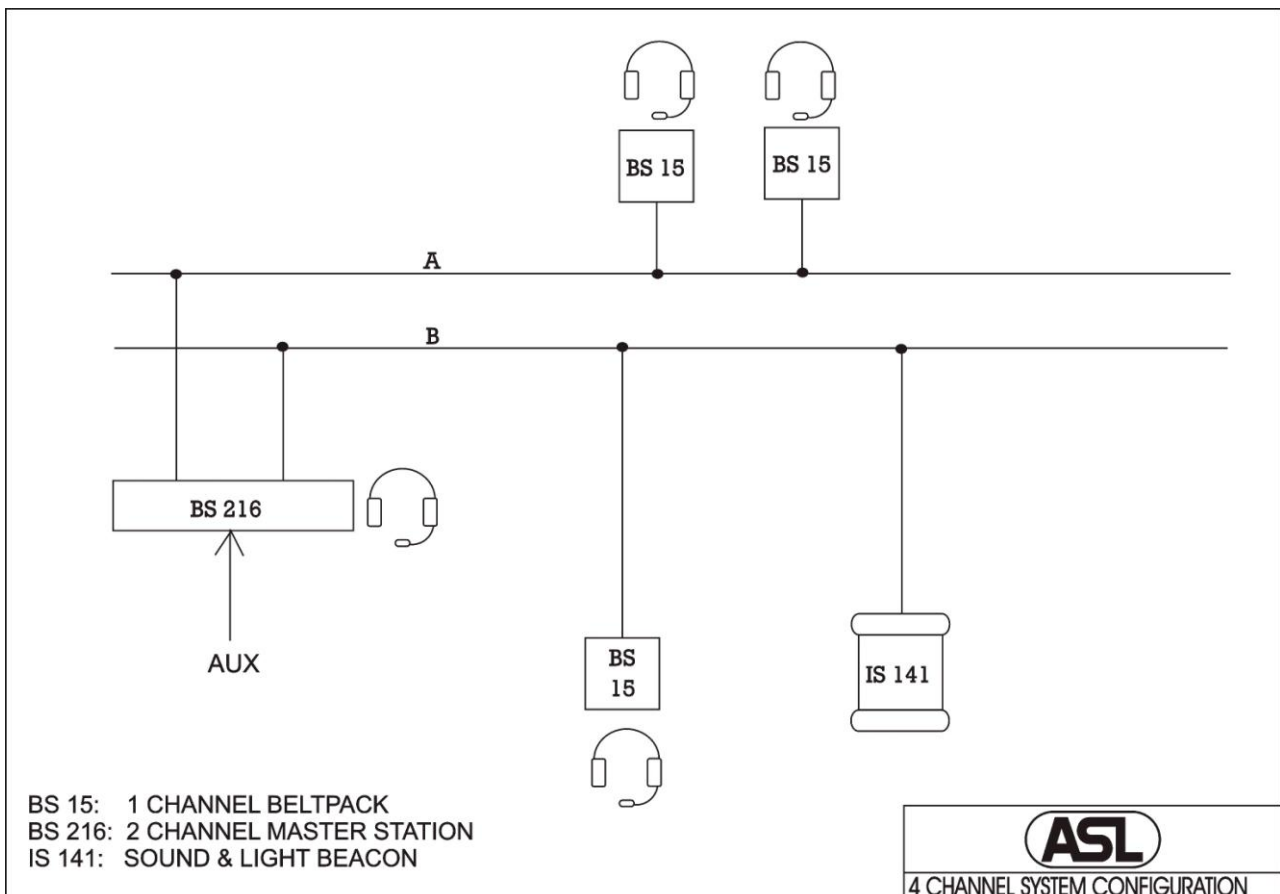

13.0 BLOCK DIAGRAM BS 15

